

Kinetrol EL Positioner Ordering Codes

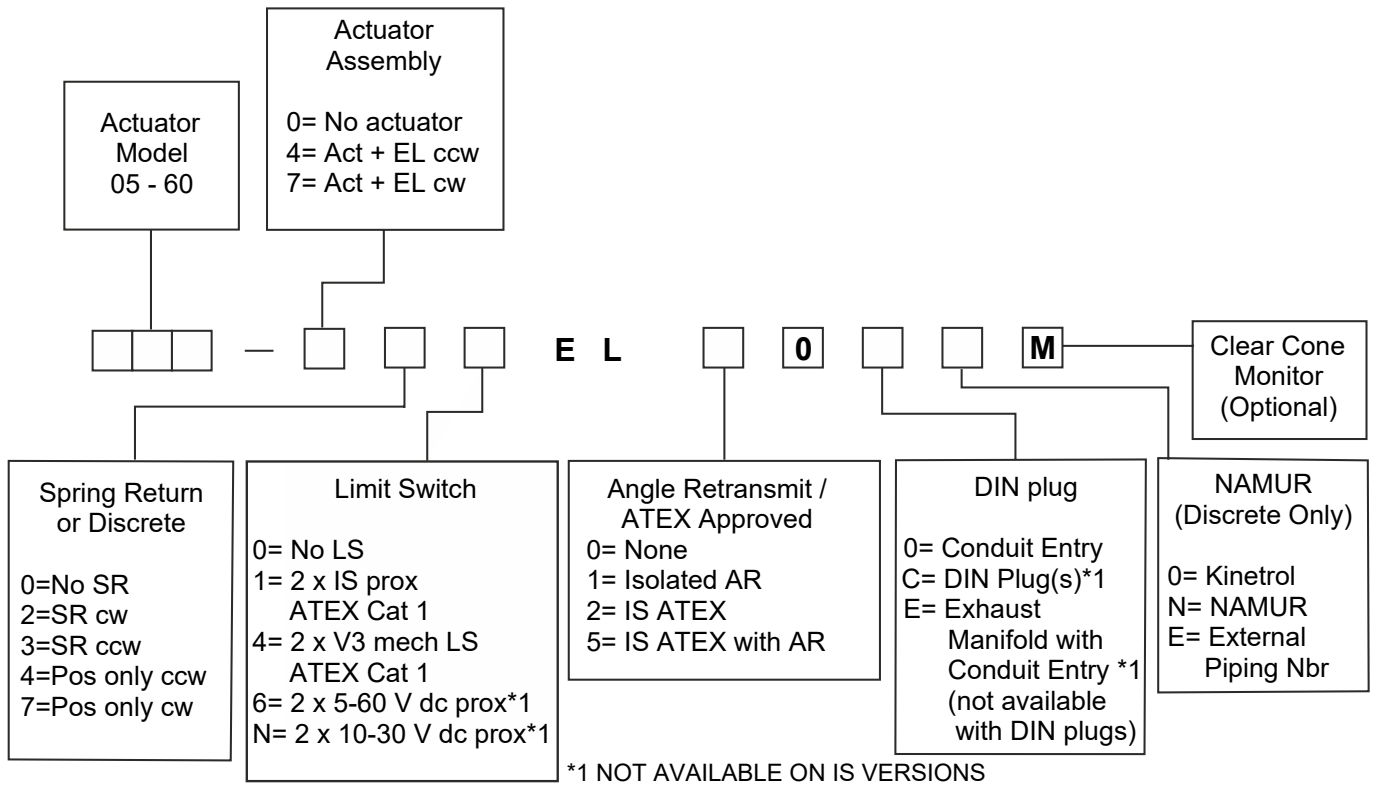

Counter clockwise on rising signal is determined looking down on positioner

Examples

- 004-040EL000N Discrete counter clockwise (ccw) EL with NAMUR.
- 054-404EL0000M 05 Double acting actuator with ccw EL complete with 2x V3 mech switches and clear cone monitor

