

2 Piece Full Bore Stainless Steel Ball Valve

TC125

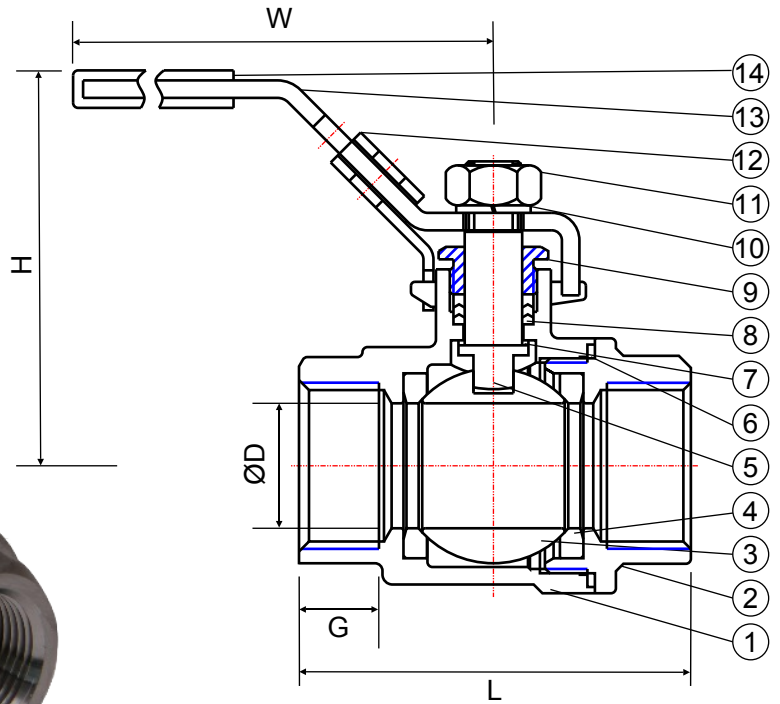
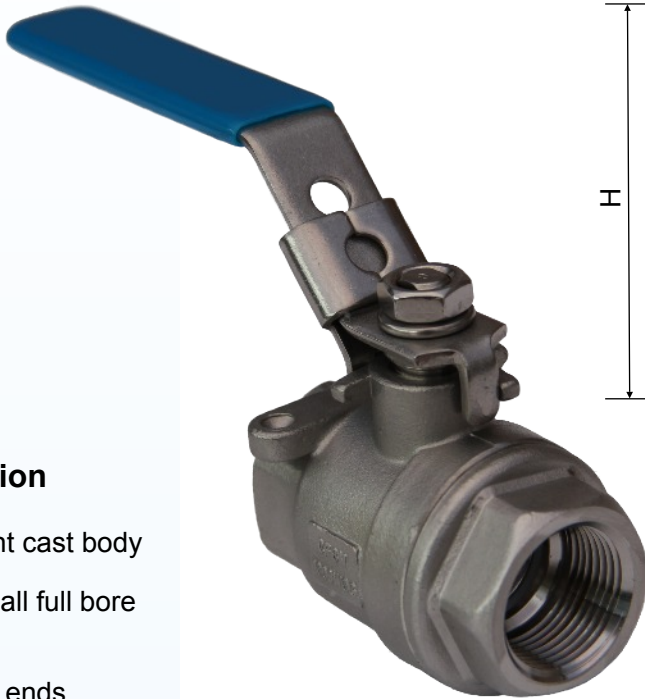

Specification

- Investment cast body
- Floating ball full bore design
- Threaded ends
 - BSPT: JIS B 0203
 - BSPP: BS 21
 - NPT: ASME B1.20.1
- Blowout proof stem design
- Anti-static device
- Cavity pressure equalising hole
- Locking device
- Inspection/test to API598/En12266
- 1000 psi W.O.G.

Materials

No.	Part Name	Material
1	Body	CF8M
2	Cap	CF8M
3	Ball	CF8M
4	Seat	PTFE
5	Stem	SUS316
6	Gasket	PTFE
7	Thrust Washer	PTFE
8	Packing	PTFE
9	Gland	SUS304
10	Spring Washer	SUS304
11	Stem Nut	SUS304
12	Locking Device	SUS304
13	Handle	SUS304
14	Plastic Cover	Plastic

Anti-static device

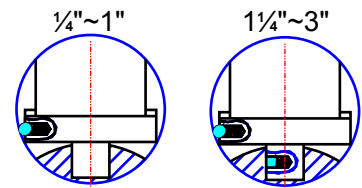

Dimensions (mm)

Size	DN	NPS	D	G	L	H	W	Cv
8	1/4"	11.6	10	52	56	102	20	
10	3/8"	12.7	10.5	52	56	102	25	
15	1/2"	15	13	58	65	123	36	
20	3/4"	20	14.5	67	68	123	67	
25	1"	25	16	78	79	153	110	
32	1 1/4"	32	17.5	90	84	153	185	
40	1 1/2"	40	19	104	93	183	266	
50	2"	50	23	127	99	183	485	
65	2 1/2"	65	28	158	136	246	840	
80	3"	80	30.5	187	146	246	1275	

Dimensions are subject to change without notice

Subject to change



Tel: 01902 780700
 Fax: 01902 780701
 Email: enquiries@powerite.co.uk
 Web: www.powerite.co.uk