

Kinetrol 180 Degree Pneumatic Actuators



ATEX Category 2

Features

- **Simple compact unit**
No external moving parts
- **Unique linkage design**
converts to 180° travel
120° option available
- **Constant gear-up ratio through travel range**
Hence constant output torque
- **Rolling contact linkage mechanism**
Ensures low wear, long life, low friction
- **Linkage sealed for life**
Protected from the environment, long maintenance free life
- **Compatible with all Kinetrol modules**
Direct mounted spring returns, limit switch boxes, positioners etc.
- **Adjustable endstops**
Giving up to 200° of travel

Operation

Kinetrol's 180° actuator is produced by adding a 2:1 step-up linkage onto the output shaft of well proven 90° vane actuators.

Factory fitted, direct mount linkage units are available to suit model 02, 03, 05, 07, 09, 12, 14 and 16 actuators, giving a neat single unit with no mount kits or brackets. The linkage's unique geometry gives constant 2:1 step-up so that the output torque remains constant throughout the actuator's travel.

The all-steel mechanism of the linkage employs rolling contacts to minimise frictional losses and wear, and to maximise life. The linkage is lubricated for life, and encased in a robust, fully sealed, die cast alloy casing. Exterior surfaces are protected by a corrosion resistant epoxy stove enamel finish. Standard adjustable endstops on the 90 degree actuator can be used to set the angle of travel. The other end of the 90 degree actuator allows the full range of Kinetrol modular accessories to be fitted directly.

120 degree actuators are also available with adjustable end stops to give up to 133° of travel for the above model range - contact Kinetrol for details.

Ordering Codes

To order a 180° actuator, add a '1' to the end of the code for the 90° actuator on which it is based and a '2' for a 120° actuator.

Examples:

To order an 074 cw spring return actuator plus 180° linkage, use code: 074-1201.

To order an 074 cw spring return actuator plus 120° linkage, use code: 074-1202.

Kinetrol 180 Degree Pneumatic Actuators

Torques

Double Acting Torques/Metric Units Nm

Actuator Model	Pressure (bar)								
	1.4	2.0	2.8	3.5	4.1	4.8	5.5	6.2	6.9
02-1001	0.6	1.1	1.6	2.2	2.7	3.2	3.7	4.2	4.8
03-1001	1.3	2.4	3.5	4.6	5.6	6.7	7.8	8.8	10.0
05-1001	3.2	5.2	7.2	9.3	11.3	13.6	15.6	17.8	19.9
07-1001	7.9	12.6	17.6	22.6	27.6	33.0	38.4	43.2	48.8
09-1001	16.3	20.0	37.1	47.6	58.0	69.2	80.4	91.2	103.0
12-1001	37.5	60.8	84.4	108.0	131.0	156.0	181.0	202.0	226.0
14-1001	97.2	151.0	206.0	262.0	316.0	375.0	434.0	488.0	542.0
16-1001	235.0	357.0	479.1	605.7	727.7	849.8	976.3	1098.4	1220.4

Double Acting Torques/English Units lbf ins

Actuator Model	Pressure (psi)								
	20	30	40	50	60	70	80	90	100
02-1001	5.6	10	14	19	24	28	33	37	42
03-1001	12	21	31	40	50	59	69	78	88
05-1001	28	46	64	82	100	120	138	157	176
07-1001	70	112	156	200	244	292	340	384	432
09-1001	144	236	328	420	512	612	712	808	912
12-1001	332	540	748	960	1160	1376	1588	1792	2000
14-1001	860	1340	1820	2320	2800	3320	3840	4320	4800
16-1001	2080	3160	4240	5360	6440	7520	8640	9720	10800

Spring Return Torques/Metric Units Nm

Actuator Model	Position of air OR spring stroke	Pressure Setting (bar)				
		3.5	4	4.5	5	5.5
02-1201	Start	1.1	1.3	1.4	1.6	1.8
	Finish	0.5	0.7	0.9	1.2	1.4
03-1201	Start	3.3	3.7	4.0	4.3	4.9
	Finish	1.0	1.5	1.9	2.2	2.8
05-1201	Start	4.9	5.5	6.2	7.0	7.9
	Finish	3.2	4.0	4.9	5.8	6.7
07-1201	Start	11.6	13.5	15.5	17.4	19.3
	Finish	7.5	9.5	11.6	13.8	16.1
09-1201	Start	23.2	27.4	31.1	35.3	39.5
	Finish	19.1	23.2	27.0	31.4	35.6
12-1201	Start	55.1	64.8	75.6	81.1	90.4
	Finish	42.2	52.0	60.0	68.9	77.5
14-1201-4900	Start	135.0	156.0	178.0	195.0	201.0
	Finish	109.0	131.0	148.0	164.0	170.0
16-1201	Start	346.8	391.0	426.0	465.0	504.3
	Finish	181.4	237.0	282.0	332.0	381.9

Spring Return Torques/English Units lbf ins

Actuator Model	Position of air OR spring stroke	Pressure Setting (psi)			
		50	60	70	80
02-1201	Start	10.3	12.2	14.1	16.0
	Finish	4.6	6.8	9.5	12.5
03-1201	Start	29.6	33.4	37.2	43.7
	Finish	8.7	13.7	19.0	24.7
05-1201	Start	44	51	61	70
	Finish	28	38	49	59
07-1201	Start	103	126	146	171
	Finish	67	92	116	143
09-1201	Start	205	251	300	351
	Finish	169	215	266	315
12-1201	Start	486	595	693	802
	Finish	374	479	585	688
14-1201-4900	Start	1200	1420	1670	1780
	Finish	969	1200	1400	1500
16-1201	Start	3069	3534	3998	4463
	Finish	1605	2197	2788	3380

Kinetrol 180 Degree Pneumatic Actuators

Dimensions

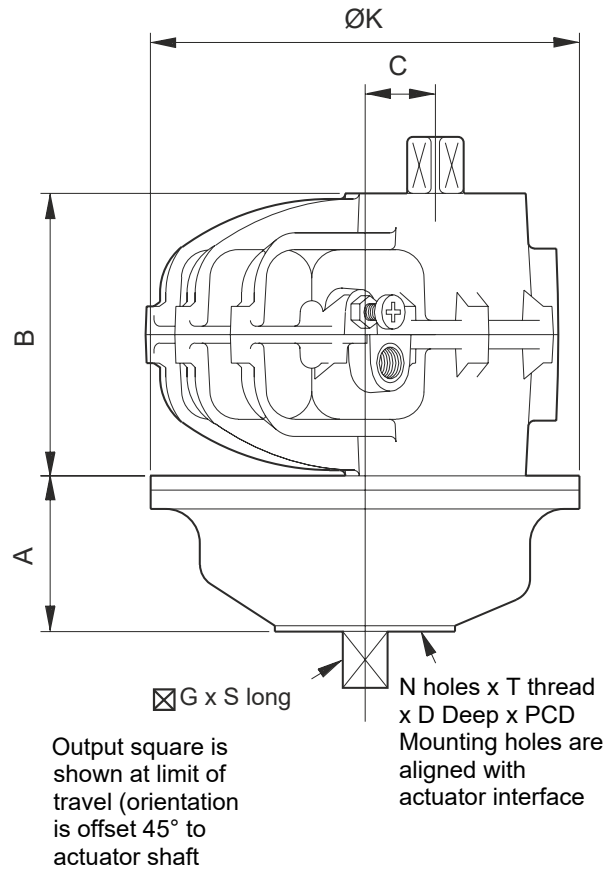

Metric Units

Actuator Model	A mm	B mm	C mm	K mm	G mm	S mm	N	T ISO	D mm	PCD mm	W kg
02 - 1001	32	50	12.5	73	8.0	10.0	4	M4	8.0	25.5	1.1
03 - 1001	36	60	20	108	9.0	12.0	4	M5	10.0	31.1	1.73
05 - 1001	42	67	20	119	9.5	13.0	6	M5	8.0	34.9	1.7
07 - 1001	59	100	25	152	16.0	20.0	4	M8	16.0	50.9	4.57
09 - 1001	70	126	35	200	19.0	26.0	4	M10	20.0	65.0	13.2
12 - 1001	99	156	45	258	25.0	31.0	4	M12	22.0	77.8	20.45
14 - 1001	125	200	70	396	28.6	38.0	4	M16	28.5	98.8	35.25
16 - 1001	176	274	100	520	41.0	55.0	4	M24	38.0	152.7	125

English Units

Actuator Model	A inch	B inch	C inch	K inch	G inch	S inch	N	T UNC	D inch	PCD inch	W lb
02 - 1001	1.24	1.97	0.49	2.87	0.315	0.39	4	8-32	0.31	1.000	2.43
03 - 1001	1.40	2.36	0.79	4.25	0.354	0.47	4	10-24	0.39	1.225	3.46
05 - 1001	1.65	2.64	0.79	4.69	0.375	0.51	6	10-24	0.31	1.375	3.75
07 - 1001	2.32	3.94	0.98	6.00	0.630	0.79	4	5/16-18	0.63	2.000	11.68
09 - 1001	2.76	4.96	1.38	7.90	0.748	1.02	4	3/8-16	0.79	2.560	29.10
12 - 1001	3.90	6.14	1.77	10.16	0.984	1.22	4	1/2-13	0.87	3.060	44.99
14 - 1001	4.92	7.87	2.76	15.59	1.125	1.50	4	5/8-11	1.13	3.890	77.55
16 - 1001	6.93	10.79	3.94	20.47	1.614	2.17	4	7/8-9	1.50	6.012	275.00

N.B. Weights are inclusive of actuator and 180 degree assembly, coupling and indicator (except models 14 & 16).