

EXPLOSION PROOF LIMIT SWITCH BOX

The Explosion Proof Limit Switch Box offers a wide range of signalling options in a compact corrosion resistant aluminium alloy housing available for close - mounting onto Kinetrol actuators or discrete mounting via a Kinetrol 05 square or industry standard VDI/VDE interface onto any make of rotary actuator. Easy to wire and set up with true industrial robustness.

Internally fitted options include AS interface digital communication and a 4-20mA, 2-wire, modulating angle retransmit circuit. The range of switches and terminal arrangements includes 2 or 4 switches and extra connections - allowing single point termination of wiring for limit switches and solenoid valves. This product is available to mount on Kinetrol models 03 - 30.

KEY FEATURES

Wide range of worldwide explosion proof approvals including IECEx, ATEX & FM (for USA & Canada). FM option also comes IEC and ATEX approved.

All units protected to IP66 / NEMA 4X / TYPE 4X.

Attractive, functional and part-spherical profile. Robust corrosion resistant, anodised & epoxy painted diecast aluminium alloy housing.

Close - mount to Kinetrol actuator models 03-15 for low profile.

Discrete Kinetrol 05 square drive insert for use with Kinetrol actuator models 16 - 30.

Discrete NAMUR drive for use with VDI/VDE 3845 drive actuators.

2 or 4 cable entries available to allow back wiring of solenoid valves.

Up to 4 switches available for SPDT, DPDT or multiple circuit operation.

Easy and accurate setting of switching position.

Optional antistatic Clear Cone Monitor available.

Integral angle retransmit circuit options are available.

Integral AS interface bus circuit option reads up to 4 switch inputs and drives up to 2 bus powered solenoids.

-40°C to +80°C ambient operating temperatures (dependent on switch options).

SPECIFICATION

NORTH AMERICAN APPROVAL

Type of protection, Explosion Proof
 US: Class I, Division 1, Gas groups B,C,D, Class II, Division 1, Dust Groups E,F,G, T5 NEMA 4X
 For Gas group A use order code "P".
 CANADA: Class I, Division 1, Gas groups B,C,D, Class II, Division 1, Dust Groups E,F,G, T5 TYPE 4X

EUROPE/GLOBAL - ATEX / IECEx APPROVAL

Protection concept, Flame Proof 'd'
 Group II C/A21, Category 2, Gas & Dust, T5, IP66

CASING

Precision diecast LM24 alloy, anodised & epoxy stove enamel.

COUPLING

Zinc plated steel.

SEALS

Fluoropolymer dynamic seals and NBR static seals.

WEIGHT

1.5 kg.

CABLE ENTRY OPTIONS

M20 x 1.5 or 1/2" 14 NPT conduit entry threads.

DIAGRAM GUIDE (opposite page)

1. STANDARD INDICATOR

Visual indication of valve position (standard supply).

2. CLEAR CONE MONITOR OPTION

High visibility position indicator shows open-closed status and/or angular position viewed from any angle above the lid. Made of robust transparent antistatic polymer fully sealed onto the metal lid.

3. LID

Made of robust epoxy-coated anodised aluminium alloy, threaded to give rapid removal with external features for easy use.

4. ENCLOSURE

Robust epoxy-coated anodised aluminium alloy with o-ring sealing. 2 or 4 conduit entry options are available.

5. COUPLING

Made from strong plated steel with easily adjusted striker clamps in reinforced polymer. Special strikers with metal inserts are used with inductive proximity sensor options.

6. STANDARD TERMINAL BLOCKS

2 x 3-way blocks accommodating up to a 2.5mm² cable fitted directly adjacent to conduit entries, plus optional third and fourth 3-way blocks for single point termination of external solenoid valve or extra limit switches. Internal and external earth terminals are also provided.

7. MULTI TERMINAL OPTION

PCB mounted option which gives 4 x 3 - way terminals, plus 3-way termination for external solenoid and 2-way termination for 4-20mA angle retransmit wiring immediately adjacent to conduit entries (up to 17 connections provided).

8. OPTIONAL AS INTERFACE CIRCUIT

The AS interface circuit fits inside the standard box to give control and monitoring by serial communication of up to 31 actuators, (61 for certain applications). All power and communications for circuits and actuator solenoid valves can be carried via one 2-wire cable. Refer to Kinetrol for details.

9. POSITIONER OPTIONS AVAILABLE

Please refer to Kinetrol for details

10. OPTIONAL ANGLE RETRANSMIT

An optional angle retransmit circuit fits inside the standard explosion proof limit switch box. Powered by a 14 - 30v DC supply, the 2 wire, loop powered circuit generates a 4-20mA current to feedback the position of the actuator. The circuit has zero and span adjustments for easy set-up and with the use of a high quality servo pot and anti backlash spring, gives a long life and high precision.

11. POTENTIOMETER

Feedback from 0 to 20K ohms at 20v maximum.

12. 05 or 03 REDUCER

Reducing square adapter from Kinetrol 07 size to 05 or 03.

13. KINETROL 05 SQUARE DRIVE

Interfaces with Kinetrol 05 vane slot without backlash.

14. NAMUR ADAPTOR

Converts standard coupling to NAMUR standard.

15. CLOSE - MOUNT PLATE

Standard plate allows close fitting to Kinetrol actuator models 03-15.

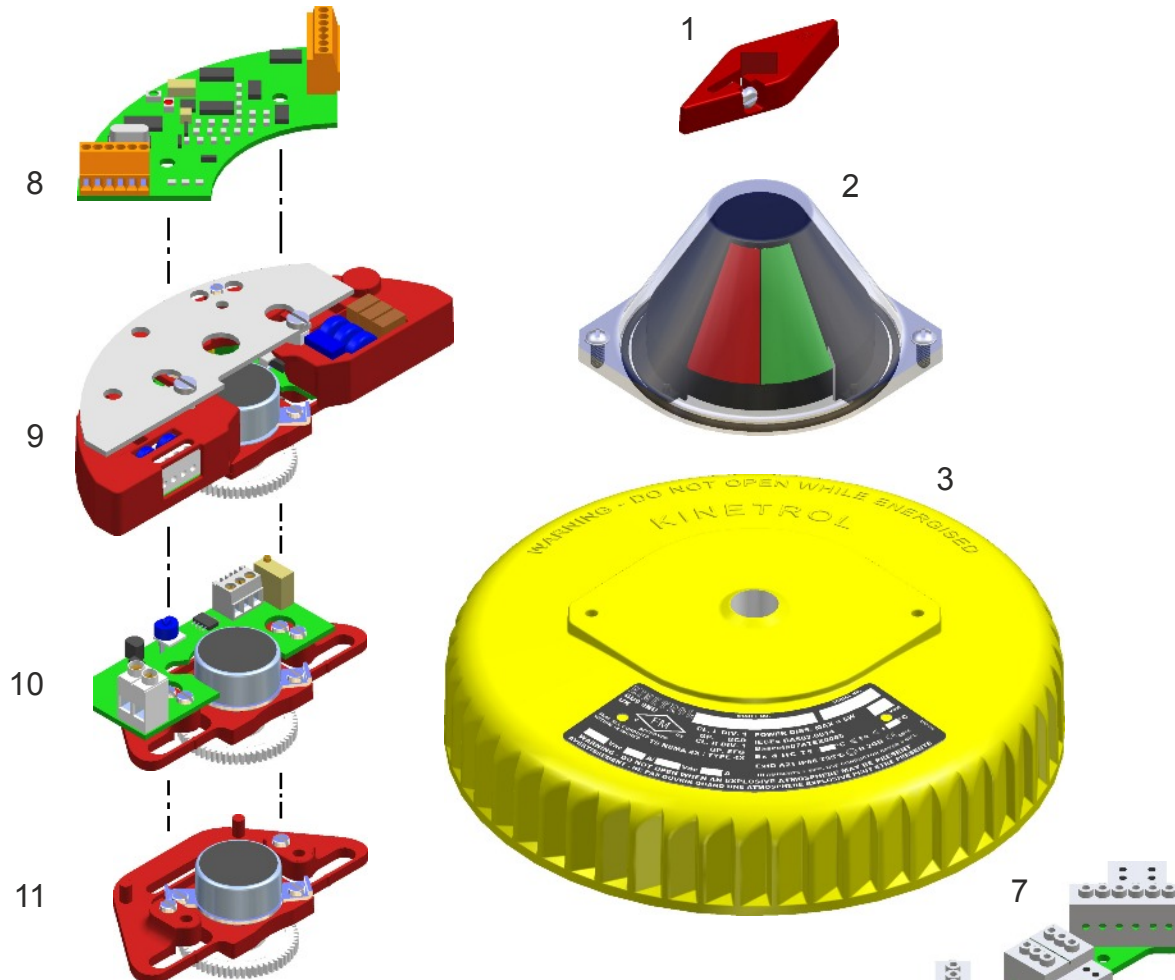

SWITCHING OPERATION CONDITIONS

Switch Code	Voltage		Current	Temperature Range
	AC	DC		
1/A	—	8	6mA	-20°C to +80°C
4/7	250	48	2.4A AC/1.8A DC	-40°C to +80°C
5/B	250	300	100mA	-25°C to +70°C
6/C	—	60	100mA	-20°C to +80°C
9/D	—	30	100mA	-40°C to +80°C
E/F	140	140	200mA	-25°C to +80°C
N	—	30	100mA	-25°C to +70°C

IECEx & ATEX - Approval type E

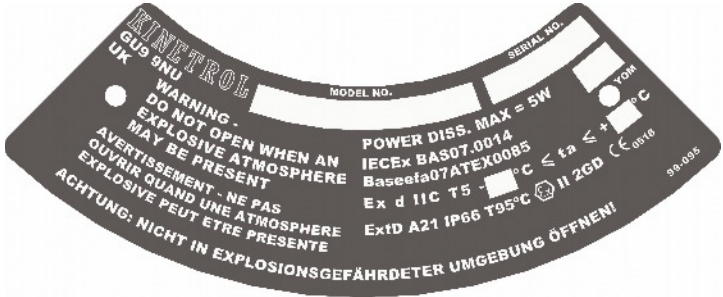

FMC/U, IECEx & ATEX - Approval type F & P

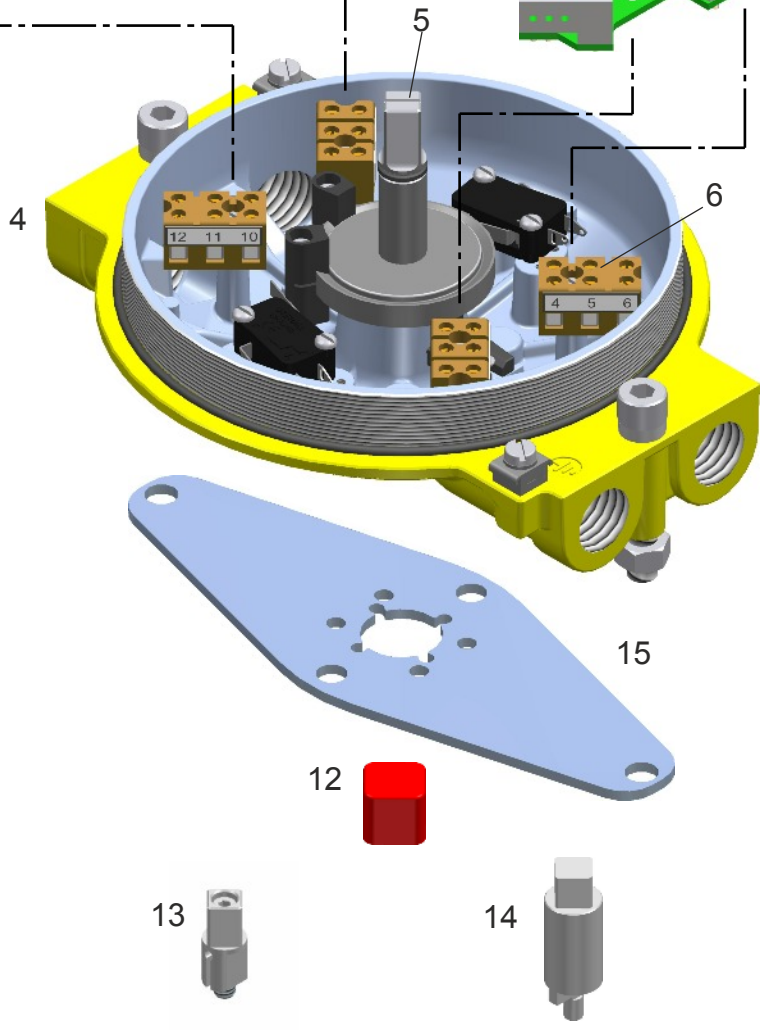
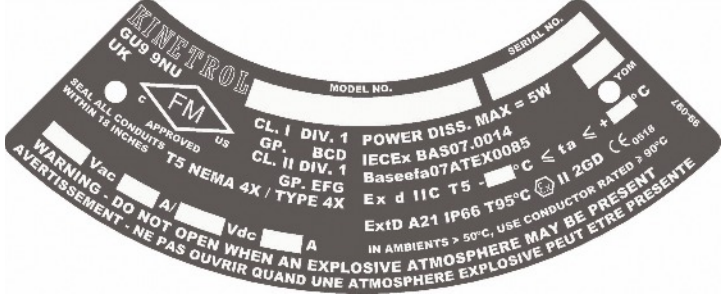

DIMENSIONS

Kinetrol Close Mount Option

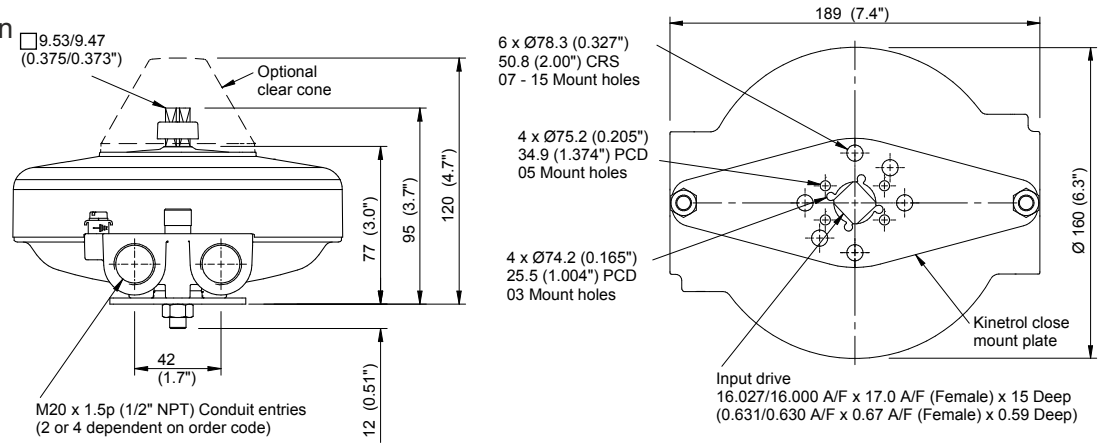

Discrete Mount Option

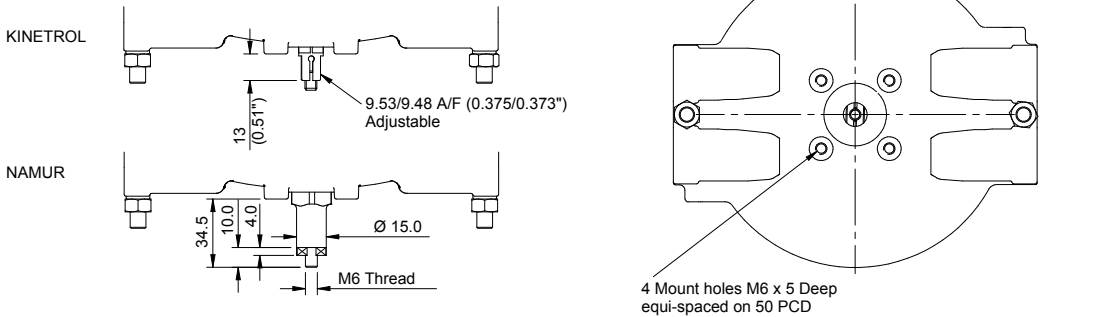

ORDERING CODES

APPROVAL TYPE
E = IEC / ATEX IIC, IIB, IIA
F = FM / FMC GRPS B,C,D
P = FM GRP A

B = 2 ENTRY
D = 4 ENTRY

SWITCH OPTIONS
(SUPPLIED WITH 2 STRIKERS AS STANDARD)
1 = 2 x V3 7.5-30Vdc, NC, 2 WIRE INDUCTIVE SENSORS
4 = 2 x V3 SPDT, 0-250Vac, MECHANICAL MICROSWITCHES
5 = 2 x V3 20-250Vac / 10-300Vdc NO, 2 WIRE, INDUCTIVE SENSORS
6 = 2 x V3 5-60Vdc, NO, 2 WIRE, INDUCTIVE SENSORS
7 = 4 x CODE 4 MICROSWITCHES
9 = 2 x V3 SPDT, 0-250Vac, GOLD PLATED CONTACTS
MECHANICAL MICROSWITCHES
A = 4 x CODE 1 SENSORS
B = 4 x CODE 5 SENSORS
C = 4 x CODE 6 SENSORS
D = 4 x CODE 9 MICROSWITCHES
E = 2 x V3 20-140Vac / 10-140Vdc, NO, 2 WIRE, INDUCTIVE SENSORS
F = 4 x CODE E SENSORS
N = 2 x 10-30Vdc, PNP, 3 WIRE, PROXIMITY SENSORS

ACTUATOR MODEL 03 - 30
0 = NO SR
2 = SR CW
3 = SR CCW

ACTUATOR MODEL 03 - 30
0 = WITHOUT ACT
1 = WITH ACT

ACTUATOR MODEL 03 - 30
0 = NO SR
2 = SR CW
3 = SR CCW

TERMINALS NEEDED FOR OPTIONS
NO BACKWIRING
ASI + 2 OR 4 SWITCHES = 2x3 (0)
A/R + 2 SWITCHES = 2x3 (0)
A/R + 4 SWITCHES = PCB (6)
POT + 2 OR 4 SWITCHES = PCB (6)
2 SWITCHES = 2x3 (0)
4 SWITCHES = 4x3 (5)

WITH BACKWIRING
A/R + 2 SWITCHES = PCB (6)
A/R + 4 SWITCHES = PCB (6)
POT + 2 SWITCHES = PCB (6)
POT + 4 SWITCHES = PCB (6) SEE NOTE
2 SWITCHES = 3x3 (4)
4 SWITCHES = PCB (6)

NOTE - POT + 4 SWITCHES WITH BACKWIRING WILL NOT HAVE ENOUGH TERMINAL CONNECTORS TO WIRE ALL NORMALLY OPEN / NORMALLY CLOSED SWITCH CONNECTIONS WITH 3 POT CONNECTIONS

0 = NO OPTIONS
B = ASI BUS
C = ASI EXTENDED ADDRESSING OUTPUTS DISABLED
D = ASI EXTENDED ADDRESSING OUTPUTS ENABLED
E = ASI EXTENDED ADDRESSING OUTPUTS ENABLED, SEPARATE POWER SUPPLY
F = ANGLE RETRANSMIT CLOCKWISE
G = ANGLE RETRANSMIT ANTI-CLOCKWISE
P = POTENTIOMETER

0 = CLOSE-MOUNT (03-14 MODEL-SPECIFIC)
1 = DISCRETE KINETROL 05 SQUARE DRIVE (16-30 MODEL-SPECIFIC)
2 = DISCRETE NAMUR
3 = NO MOUNTING PARTS (NON MODEL-SPECIFIC)

NOTE: ACTUATORS 16 - 30 REQUIRE DISCRETE MOUNTING

MOUNTING PARTS AVAILABLE:
SP1601 - 05 SQUARE DRIVE
SP1602 - 07/05 SQUARE REDUCER
SP1603 - NAMUR DRIVE
SP1604 - 07/03 SQUARE REDUCER
SP/ASP1607 - CLOSE MOUNTING KIT
SP/ASP1608 - 12/14/15 ACCESSORY MOUNTING ADAPTOR (UNDRILLED)
SP/ASP389 - MODEL 16 MOUNT KIT
SP/ASP329 - MODEL 18 MOUNT KIT
SP/ASP400 - MODEL 20/30 MOUNT KIT

0 = 2 x 3 TERMINALS
4 = 3 x 3 TERMINALS
5 = 4 x 3 TERMINALS
6 = MULTI-TERMINAL PCB (2x6 + 1x3 + 1x2)

0 = STANDARD INDICATOR
A = ANTI-STATIC MONITOR

3 = DIN FLANGE STANDARD (FEMALE DRIVE)
4 = ISO (M20) THREAD
A = DIN FLANGE STANDARD WITH NAMUR ADAPTOR
B = ISO (M20) THREAD STANDARD WITH NAMUR ADAPTOR
C = ANSI (1/2" NPT) THREAD STANDARD WITH NAMUR ADAPTOR
7 = ANSI THREAD (1/2" NPT)

NOT AVAILABLE WITH APPROVAL TYPES F & P

KINETROL®



The Explosion Proof Limit Switch Box



Kinetrol Ltd, Trading Estate, Farnham, Surrey. GU9 9NU, England.
Tel: 01252 733838 Fax: 01252 713042
E-mail: sales@kinetrol.com Web Site: www.kinetrol.com
Copyright 2014 Kinetrol Ltd.