

# SWING CHECK VALVE 15mm - 200mm(1/2inch - 8inch)



15mm(1/2inch), 20mm(3/4inch)



25mm(1inch) - 200mm(8inch)

## FEATURES

- The SWING CHECK VALVE prevents backflow, thus protecting equipment, such as a pump.
- Being of a swing arm type, the valve gives little resistance to flow.
- The SWING CHECK VALVE is highly resistant to corrosive chemicals, acid and alkaline, because of its plastic construction.
- To maintain the SWING CHECK VALVE, only the bonnet lid has to be removed, without taking the body out of pipeline.

## MATERIAL AND WORKING TEMPERATURE RANGES

Body material	Working Temperature °C (°F)	Max. Working Pressure (at R.T.) MPa[kgf/cm <sup>2</sup> ] [PSI]		
		15(1/2inch) - 80(3inch)	100(4inch) - 150(6inch)	200(8inch)
HI-PVC	0 - 50 (30 - 120)	1.0 {10.2} [150]	0.7 {7.1} [100]	0.5 {5.1} [70]
PP	-20 - 80 (-5 - 175)	1.0 {10.2} [150]	0.7 {7.1} [100]	0.5 {5.1} [70]
PVDF	-20 - 100 (-5 - 210)	1.0 {10.2} [150]	0.7 {7.1} [100]	0.5 {5.1} [70]

## PARTS & MATERIALS O-ring Type

### ● PP

No.	DESCRIPTION	Pcs.	MATERIAL	REMARKS
①	BODY	1	PP	
②	BONNET	1	PP	
③	SHAFT	1	PP	
④	PLUG	1	PP	
⑤	⑤a DISC	1	PVDF	
	⑤b SEAT HOLDER	1	PP	
	⑤c BOLT(A)	-	PP	Used for Size 25~200mm
	⑤d ARM	1	PP	Used for Size 25~200mm
	⑤e WASHER	1	PP	Used for Size 25~200mm
	⑤f NUT(A)	1	PVDF	Used for Size 25~200mm
	⑤g PIN	1	PVDF	In Case Material is PVDF, Used for Size 65~200mm
	⑤h BOLT(B)	1	PP	Used for Size 15, 20mm
	⑤i NUT(B)	1	PP	Used for Size 15, 20mm
	⑤j SEAT	1	GASKET, SEAT, O-RING(A)/O-RING(B)	Used for Size 15, 20mm
⑦	GASKET(B)	1	EPDM/EPDM FKM/FKM	
⑧	O-RING(B)	1	PTFE/FKM-F* <sup>※2</sup> PTFE/PFA* <sup>※1, ※2</sup>	※1 FKM Covered at PFA ※2 Special request
⑨	BOLT · NUT	-	STAINLESS STEEL(SUS304)	Used for Size 25~200mm
⑩a	BODY RING	-	STAINLESS STEEL(SUS304)	Used for Size 15, 20mm

Note : 1) ⑩a Body-ring is available for PP Body 15mm(1/2inch) · 20mm(3/4inch).

### ● HI-PVC, PVDF

No.	DESCRIPTION	Pcs.	MATERIAL	REMARKS
①	BODY	1	HI-PVC, PVDF	
②	BONNET	1	HI-PVC, PVDF	
③	SHAFT	1	HI-PVC, PVDF	
④	PLUG	1	HI-PVC, PVDF	
⑤	⑤a DISC	1	HI-PVC, PVDF	
	⑤b SEAT HOLDER	1	HI-PVC, PVDF	
	⑤c BOLT(A)	-	HI-PVC, PVDF	Used for Size 25~200mm
	⑤d ARM	1	HI-PVC, PVDF	Used for Size 25~200mm
	⑤e WASHER	1	HI-PVC, PVDF	Used for Size 25~200mm
	⑤f NUT(A)	1	HI-PVC, PVDF	Used for Size 25~200mm
	⑤g PIN	1	HI-PVC, PVDF	In Case Material is PVDF, Used for Size 65~200mm
	⑤h BOLT(B)	1	HI-PVC, PVDF	Used for Size 15, 20mm
	⑤i NUT(B)	1	HI-PVC, PVDF	Used for Size 15, 20mm
	⑤j SEAT	1	GASKET, SEAT, O-RING(A)/O-RING(B)	Used for Size 15, 20mm
⑦	GASKET(B)	1	FKM/FKM PTFE/PFA* <sup>※1</sup>	※1 FKM Covered at PFA ※2 Special request
⑧	O-RING(B)	1	PTFE/FKM-F* <sup>※2</sup> PTFE/FKM-C* <sup>※2</sup>	
⑨	BOLT · NUT	-	STAINLESS STEEL(SUS304)	Used for Size 25~200mm

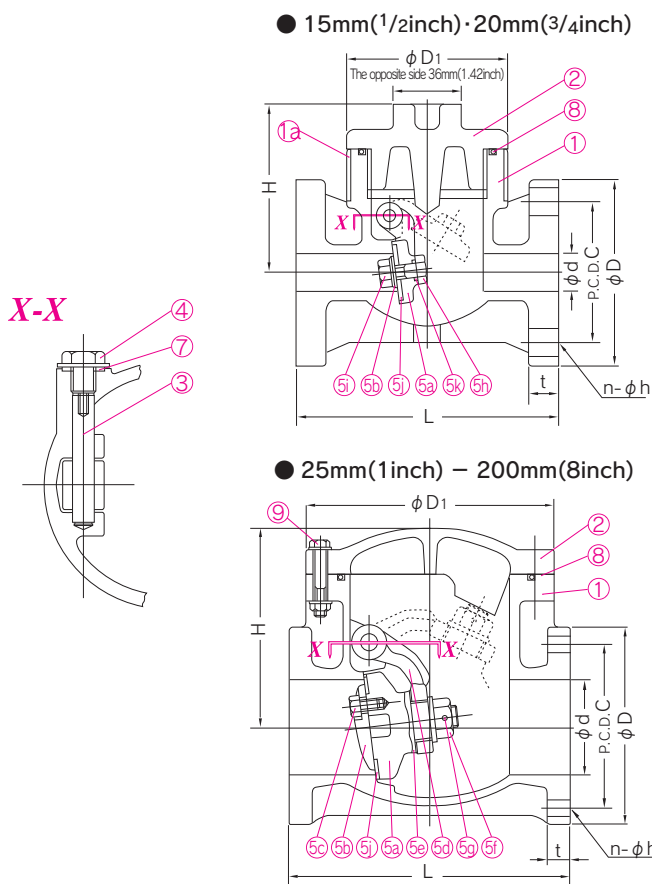

WORKING PRESSURE VS. TEMPERATURE

SWING CHECK VALVE O-ring Type

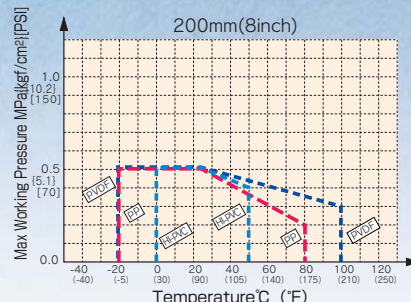
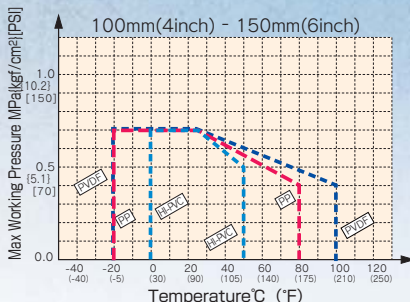
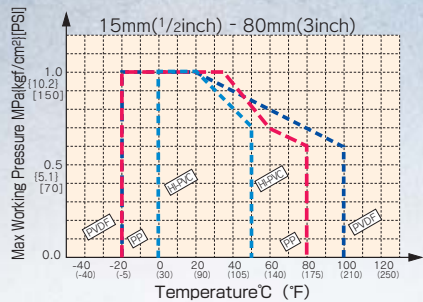

DIMENSIONS TABLE

JIS		Unit:mm														
Nominal Size		d	JIS 5K				JIS 10K				D <sub>1</sub>	L	t			H
mm	inch		D	C	n	h	D	C	n	h			HI-PVC	PP	PVDF	
15	1/2	20	80	60	4	12	95	70	4	15	86	140	15	15	15	87
20	3/4	20	85	65	4	12	100	75	4	15	86	140	15	15	15	87
25	1	25	95	75	4	12	125	90	4	19	130	160	16	16	16	117
32	1 1/4	40	-	-	-	-	135	100	4	19	145	180	18	17	18	135
40	1 1/2	40	120	95	4	15	140	105	4	19	145	180	18	17	18	135
50	2	50	130	105	4	15	155	120	4	19	180	200	20	20	21	161
65	2 1/2	65	155	130	4	15	175	140	4	19	200	240	22	22	23	165
80	3	80	180	145	4	19	185	150	8	19	205	260	22	22	23	168
100	4	100	200	165	8	19	210	175	8	19	265	300	24	24	26	210
125	5	125	235	200	8	19	250	210	8	23	330	350	24	25	26	245
150	6	150	265	230	8	19	280	240	8	23	370	400	25	26	27	280
200	8	200	320	280	8	23	330	290	12	23	425	500	30	31	33	333

DIN		Unit:mm											
Nominal Size		d	DIN PN10				D <sub>1</sub>	L	t			H	
mm	inch		D	C	n	h			HI-PVC	PP	PVDF		
15	1/2	20	95	65	4	14	86	140	15	15	15	87	
20	3/4	20	105	75	4	14	86	140	15	15	15	87	
25	1	25	115	85	4	14	130	160	16	16	16	117	
32	1 1/4	40	140	100	4	18	145	180	18	17	18	135	
40	1 1/2	40	150	110	4	18	145	180	18	17	18	135	
50	2	50	165	125	4	18	180	200	20	20	21	161	
65	2 1/2	65	185	145	4	18	200	240	22	22	23	165	
80	3	80	200	160	8	18	205	260	22	22	23	168	
100	4	100	220	180	8	18	265	300	24	24	26	210	
125	5	125	250	210	8	18	330	350	24	25	26	245	
150	6	150	285	240	8	22	370	400	25	26	27	280	
200	8	200	340	295	8	22	425	500	30	31	33	333	

ANSI		Unit:inch											
Nominal Size		d	ANSI CLASS 150				D <sub>1</sub>	L	t			H	
inch	mm		D	C	n	h			HI-PVC	PP	PVDF		
1/2	15	0.79	3.50	2.38	4	0.62	3.39	5.51	0.59	0.59	0.59	3.43	
3/4	20	0.79	3.88	2.75	4	0.62	3.39	5.51	0.59	0.59	0.59	3.43	
1	25	0.98	4.25	3.12	4	0.62	5.12	6.30	0.63	0.63	0.63	4.61	
1 1/4	32	-	-	-	-	-	-	-	-	-	-	-	
1 1/2	40	1.57	5.00	3.88	4	0.62	5.71	7.09	0.71	0.67	0.71	5.32	
2	50	1.97	6.00	4.75	4	0.75	7.09	7.87	0.79	0.79	0.83	6.34	
2 1/2	65	2.56	7.00	5.50	4	0.75	7.87	9.45	0.87	0.87	0.91	6.50	
3	80	3.15	7.50	6.00	4	0.75	8.07	10.24	0.87	0.87	0.91	6.62	
4	100	3.94	9.00	7.50	8	0.75	10.43	11.81	0.94	0.94	1.02	8.27	
5	125	4.92	10.00	8.50	8	0.88	12.99	13.78	0.94	0.98	1.02	9.65	
6	150	5.91	11.00	9.50	8	0.88	14.57	15.75	0.98	1.02	1.06	11.03	
8	200	7.87	13.50	11.75	8	0.88	16.73	19.69	1.18	1.22	1.30	13.11	

\* Important: The swing check valve can be used in both vertical and horizontal pipelines. However, when installing the valve, be sure to make the direction of the arrow embossed on the valve agree with that of flow.  
 \* Swing check valves 15mm(1/2inch) and 30mm(1 1/4inch) mm in nominal size are made out of those in 20mm(3/4inch) and 40mm(1 1/2inch) in nominal size, respectively.  
 Note : For pressure limits by fluid temperature ranges and materials, see "WORKING PRESSURE VS. TEMPERATURE" in this catalog.